

# Dehumidifier Consorb **DC-31 T10, T16**



*Dehumidifying capacity at 20°C / 60%RH*

**1.4 - 2.1 kg/h**

*Dry air flow*

**300 - 490 m<sup>3</sup>/h**

- Washable rotor
- No desiccant carry-over
- Stainless steel chassis
- Self-regulating heater
- Easy to maintain
- Long lifetime

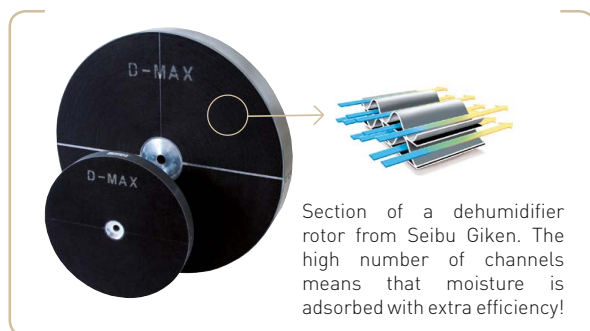

TECHNICAL DATA

Dehumidifier model	DC- 31 T10	DC-31 T16
Nominal capacity <sup>1</sup> (kg/h)	1.4	2.1
Dry air flow <sup>2</sup> (m <sup>3</sup> /h)	300	490
Wet air flow <sup>2</sup> (m <sup>3</sup> /h)	120	120
Heater current <sup>3</sup> (A)	8	13
Maximum electric consumption (kW)	2.1	3
Supply fuse 230V / 50Hz, (A)	10	16
Weight (kg)	30	32

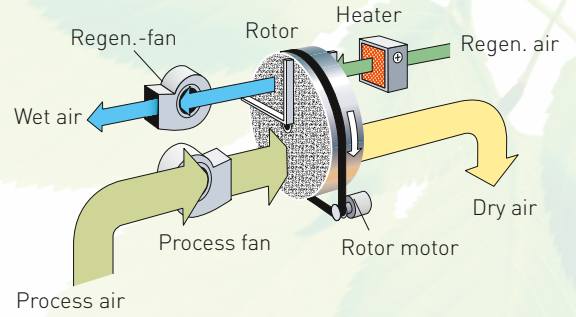

- <sup>1</sup> Valid for inlet conditions 20°C/ 60%RH. For other inlet conditions, the capacity can be calculated by using the correction factor from the diagram shown below
- <sup>2</sup> Volume flow for density 1.20 kg/m<sup>3</sup>. Free blowing
- <sup>3</sup> The design of the PTC heater enables the power to be regulated by controlling the wet air flow.

CORRECTION DIAGRAM

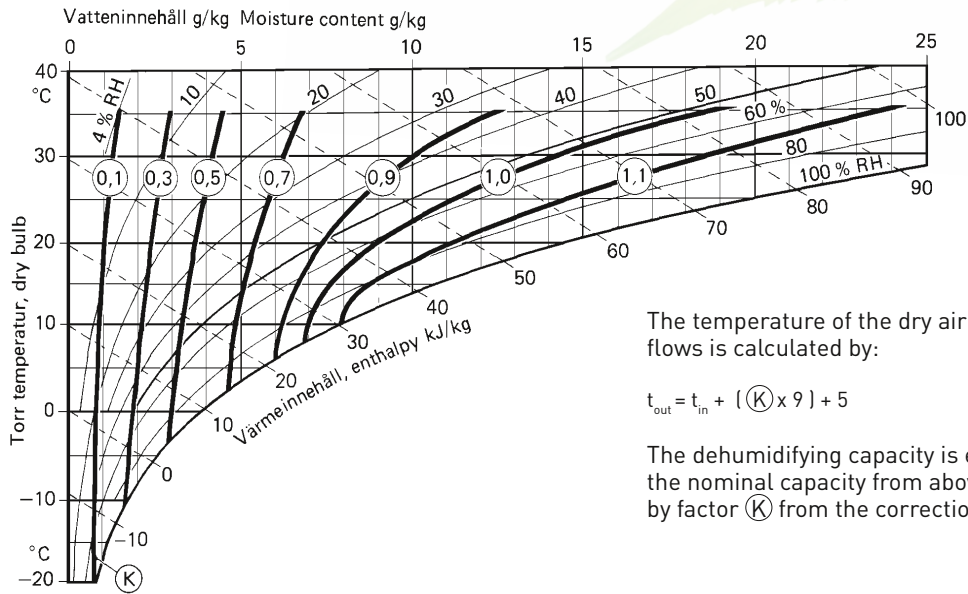

The temperature of the dry air at nominal air flows is calculated by:

$$t_{out} = t_{in} + (K \times 9) + 5$$

The dehumidifying capacity is estimated as the nominal capacity from above, multiplied by factor **K** from the correction diagram.

DIMENSIONS

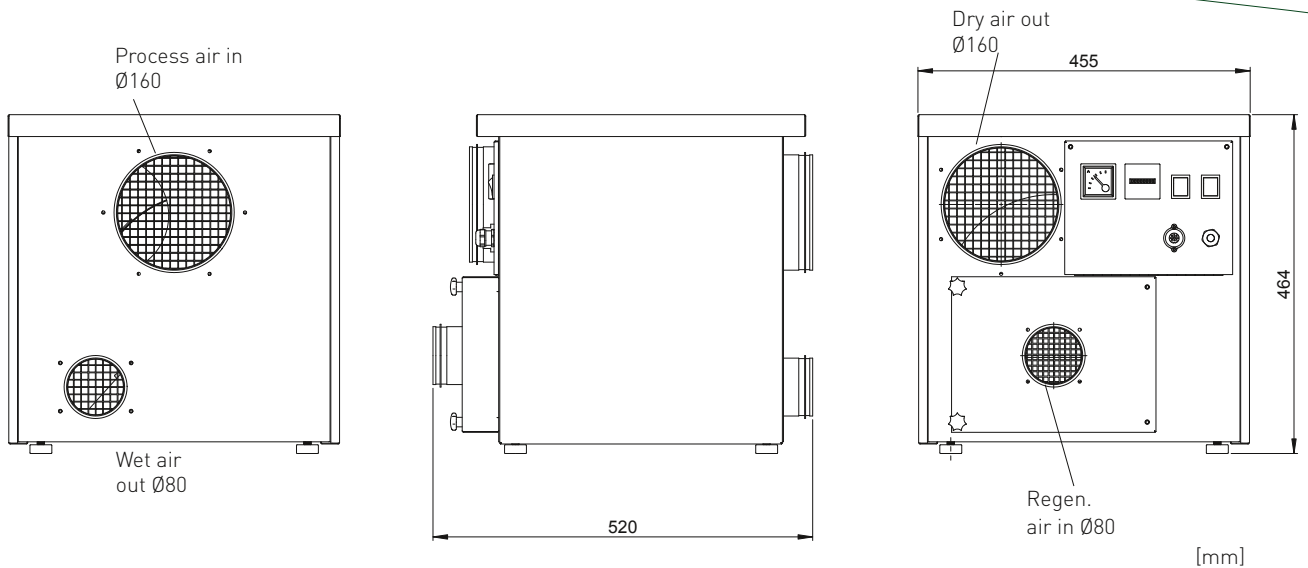

Subject to change without notice. Download installation drawing at [www.dst-sg.com](http://www.dst-sg.com)