

Dehumidifier Recusorb

DR- 40 T10 / 40 T16 / 50 R



Dehumidifying capacity at 20°C / 60%RH

1.6 - 2.8 kg/h

Dry air flow

550 - 600 m³/h

- ✓ Washable rotor
- ✓ No desiccant carry-over
- ✓ Stainless steel chassis
- ✓ Easy to maintain
- ✓ Long lifetime
- ✓ Built-in heat recovery

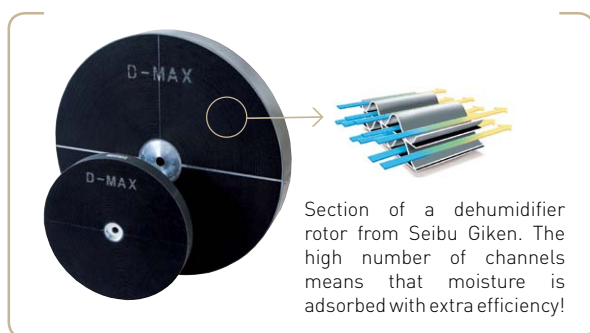

TECHNICAL DATA

Dehumidifier model	DR - 40 T10	DR - 40 T16	DR - 50R
Nominal capacity ¹ (kg/h)	1.6	2.3	2.8
Dry air flow ² (m ³ /h)	600	550	600
Static pressure at disposal (Pa)	150	150	150
Wet air flow ² (m ³ /h)	120	150	180
Static pressure at disposal (Pa)	200	150	100
Heater current (A)	8 ⁵	13 ⁵	-
Heater power [kW]	-	-	4
Total power (kW)	2.3	3.2	4.2
Supply fuse (A)	10 ³	16 ³	10 ⁴
Weight (kg)	45	45	60

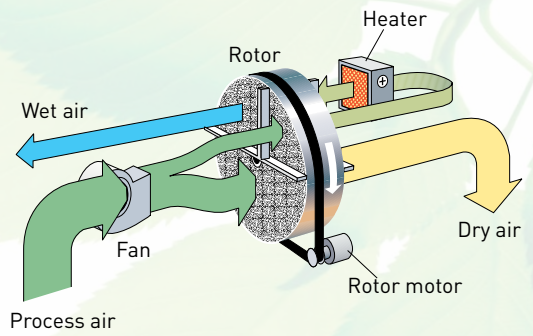

- ¹ Valid for inlet conditions 20°C/60%RH. For other inlet conditions the capacity can be calculated by using the correction factor from the diagram shown below.
- ² Volume flow for density 1.20 kg/m³.
- ³ Supply fuse 1 x 230 V 50 Hz
- ⁴ Supply fuse 3 x 400 V 50 Hz For 3 x 230 V 50Hz:16A. No neutral
- ⁵ The design of the PTC heater enables the power to be regulated by controlling the wet air flow.

CORRECTION DIAGRAM

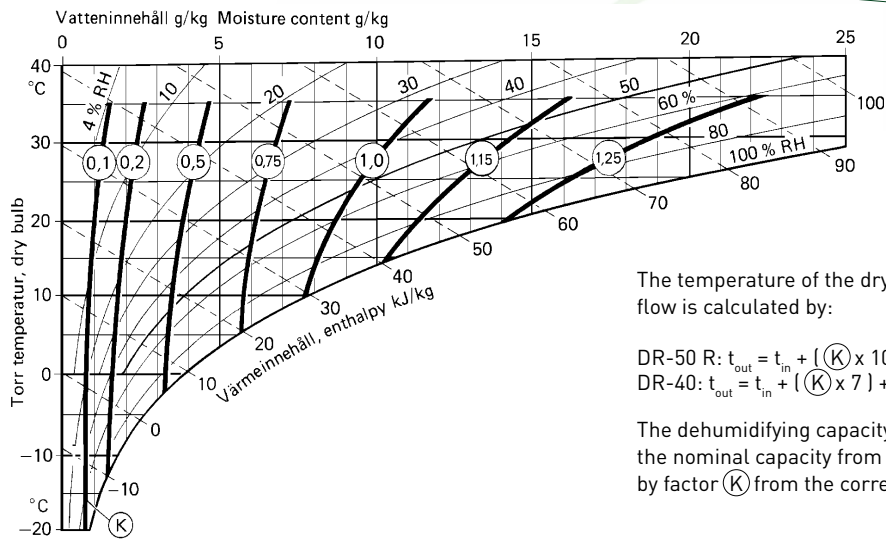

The temperature of the dry air at nominal air flow is calculated by:

$$\text{DR-50 R: } t_{\text{out}} = t_{\text{in}} + [(K) \times 10] + 3^\circ\text{C}$$

$$\text{DR-40: } t_{\text{out}} = t_{\text{in}} + [(K) \times 7] + 3^\circ\text{C}$$

The dehumidifying capacity is estimated as the nominal capacity from above, multiplied by factor (K) from the correction diagram.

DIMENSIONS

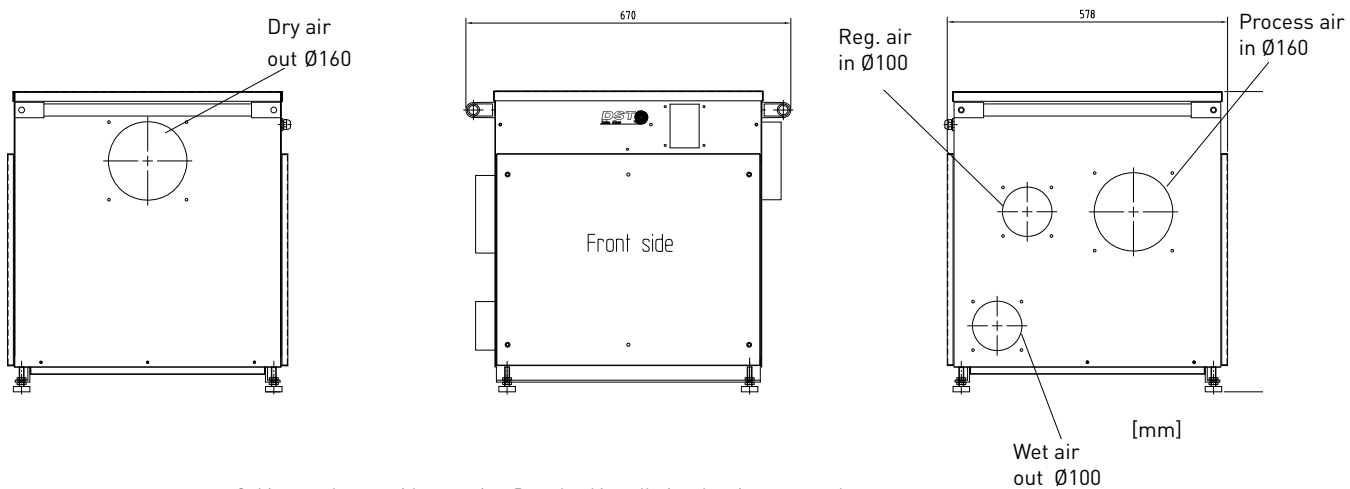

Subject to change without notice. Download installation drawing at www.dst-sg.com

Seibu Giken DST AB

Avestagatan 33 | SE-163 53 Spånga, Sweden

Tel +46 8 445 77 20 | Fax +46 8 445 77 39

www.dst-sg.com | info@dst-sg.com