

Rotor units

RU 060-102

- ✎ The desiccant D-Max rotor
- ✎ Geared drive motor with belt transmission
- ✎ Stainless steel chassis
- ✎ Sector seals

These high quality desiccant units are specially designed with a stainless steel chassis for building into customised air handling systems where a standard dehumidifier does not fit or match your specifications. Using the silica gel rotor unit, complete air handling systems can be designed and manufactured to conform to almost any specification.

All rotors from Seibu Giken is supplied with a three year performance warranty, and is manufactured according to ISO 9001.



Choose between four rotors from Seibu Giken, all with unique qualities:
D-Max - rotor for standard applications
SSCR-H - bactericidal & hygienic
SSCR-CI - silicon free rotor
SZCR - zeolite rotor for low dew points



The rotor unit operates using one of these two dehumidification principles.

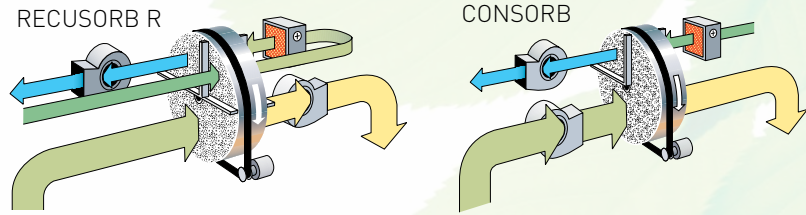

See other data sheets for larger airflows (RUF-122 -242). Optional: other rotor configurations

Technical data RU						
Model: Recusorb / Consorb	Nominal air flow* [m³/h]	Nominal capacity* [kg/h]	Height [mm]	Width [mm]	Depth [mm]	Weight [kg]
RU-060	700	3	700	700	290	40
RU-061	1300	8	700	700	340	45
RU-062	2300	15	700	700	440	57
RU-082	4400	32	920	920	440	85
RU-102	6800	50	1220	1220	440	120

* At nominal capacity and 20°C / 60%RH.

Recusorb: 60 % Process-sector, 15 % Purge-sector, 25% Reg. sector

Consorb 75/25: 75% Process-sector, 25% Reg-sector

Consorb 60/40: Process-sector 60%, Reg-sector 40%

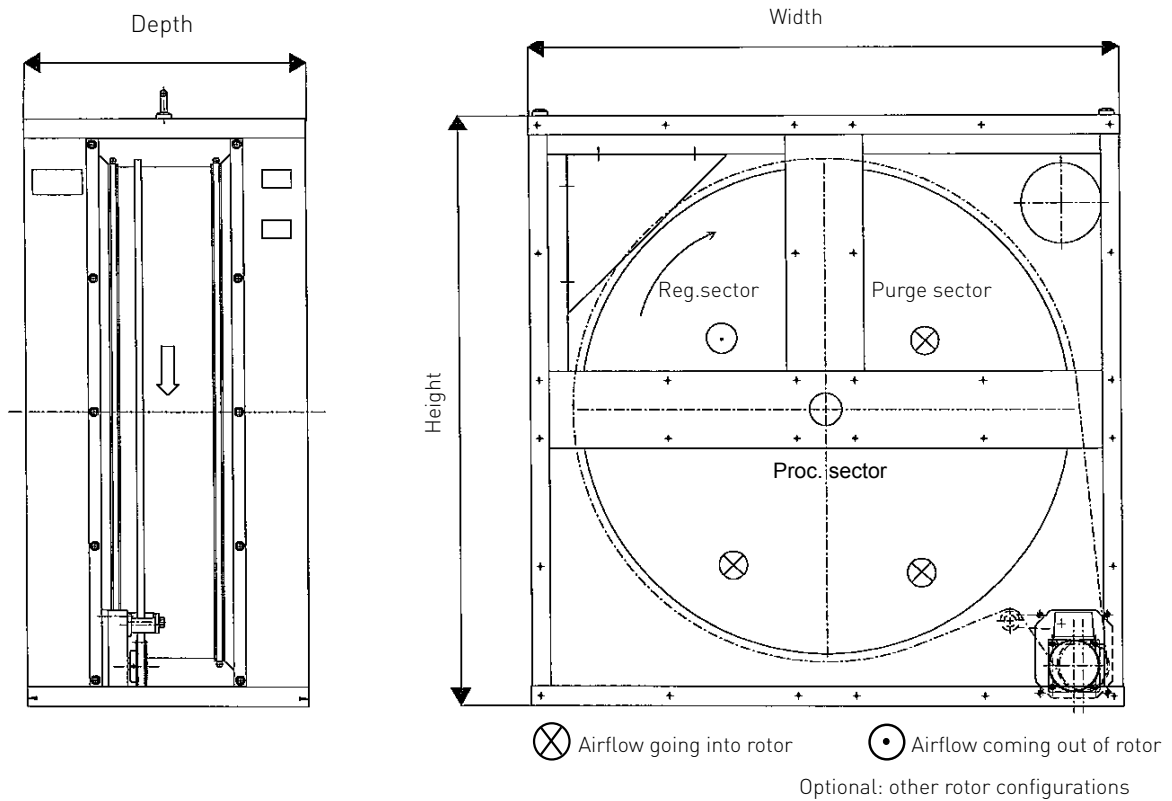

Subject to change without notice.